

Current Transducers

DIN Rail Mount Cases

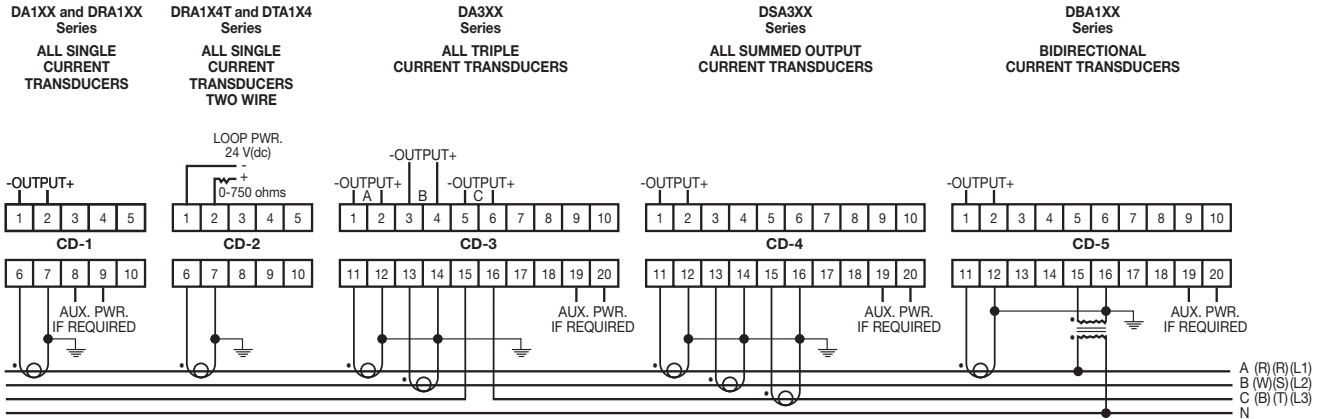

Notes:

- All 4-20 mA, 1-5 V and any other live zero output transducer must have an external (auxiliary) source of power.
- Third phase of connection drawing (CD-3) is shown as direct connect. It is typical for any transducer where the incoming signal will not exceed the rated input of the transducer.

Metal Surface Mount Cases

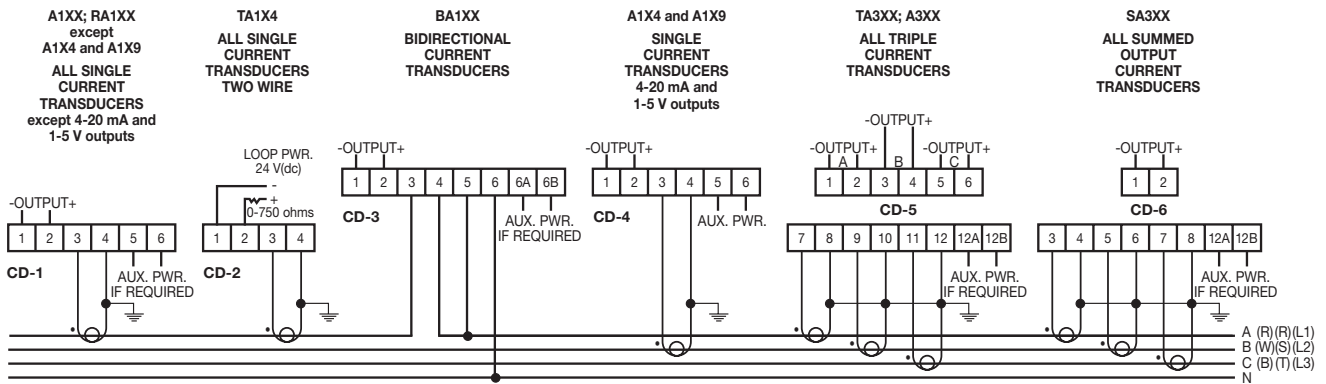

Notes:

- For supply connections use No. 14 AWG or larger wires rated for at least 75°C (167°F). Use copper conductors only.
 - All 4-20 mA and 1-5 V transducer outputs require an external (auxiliary) source of power.
 - Bi-directional Current transducer (CD-3) must be supplied with a source of AC power that is in phase with the measured current at unity power factor.
 - CD-3 is shown directly connected to the measured source. This is typical for any configuration where CTs and PTs are not used.
- Attention:**
If the transducer is mounted on a non-metallic or ungrounded surface the installer must provide the means for grounding and bonding as per NEC (National Electric Code) requirements.

Voltage Transducers

DIN Rail Mount Cases

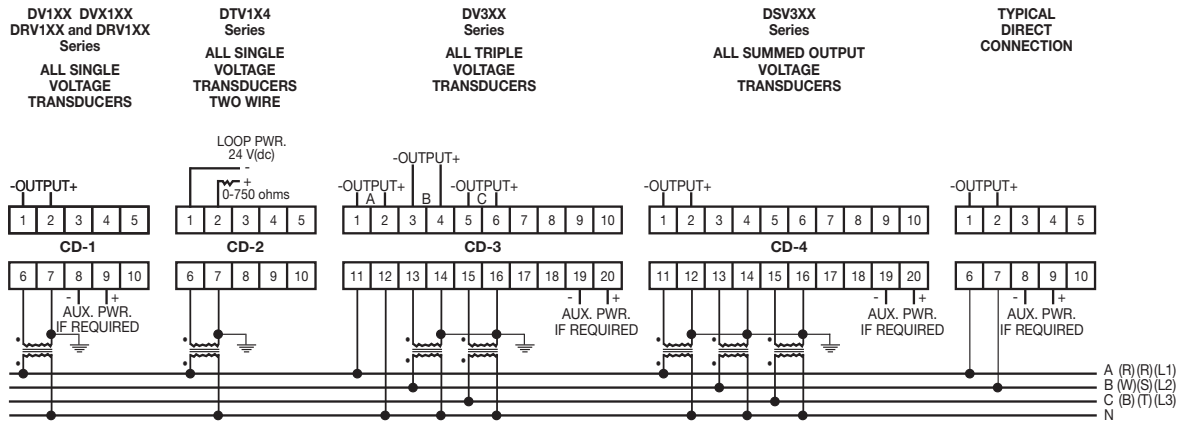

Notes:

- For supply connections use No. 14 AWG or larger wires rated for at least 75°C (167°F). Use copper conductors only.
- All 4-20 mA, 1-5 V and other live zero outputs, transducer must have an external (auxiliary) source of power.
- Third phase of connection drawing (CD-3) is shown as direct connect. It is typical for any transducer where the input will not exceed the rated input of the transducer.

Metal Surface Mount Cases

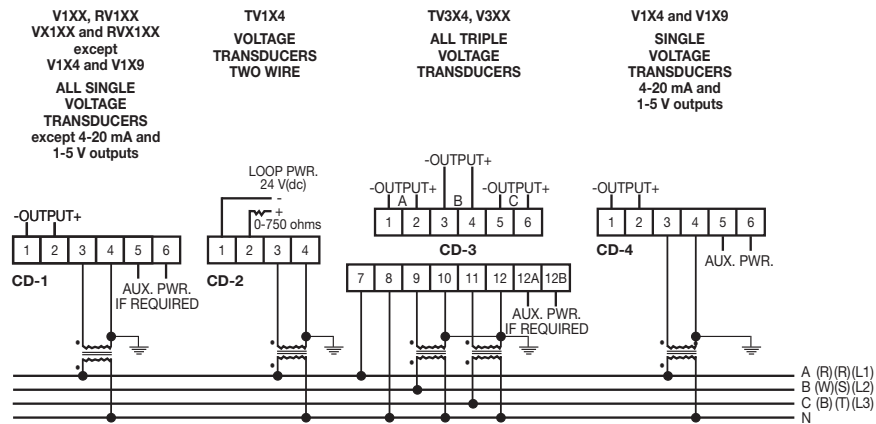

Notes:

- For supply connections use No. 14 AWG or larger wires rated for at least 75°C (167°F). Use copper conductors only.
- All 4-20 mA and 1-5 V transducer outputs require an external (auxiliary) source of power.
- CD-3 is shown with phase A directly connected to the power line; this is typical for any transducer where the input voltage does not exceed the input rating.

Attention:

If the transducer is mounted on a non-metallic or ungrounded surface the installer must provide the means for grounding and bonding as per NEC (National Electric Code) requirements.

DIN Rail Mount Cases

AC Power Transducers

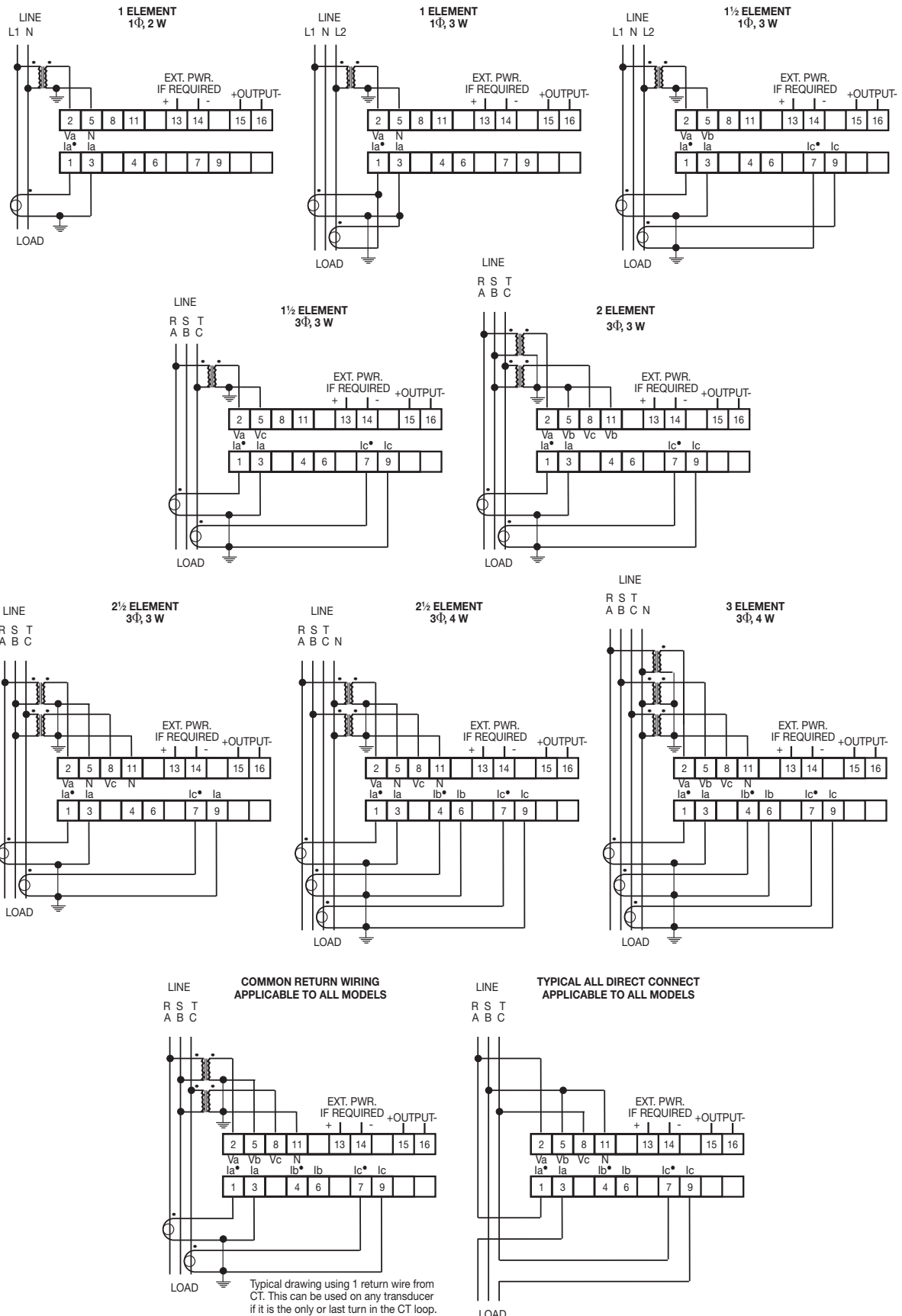

AC Power Transducers (Single Output)

Metal Surface Mount Cases

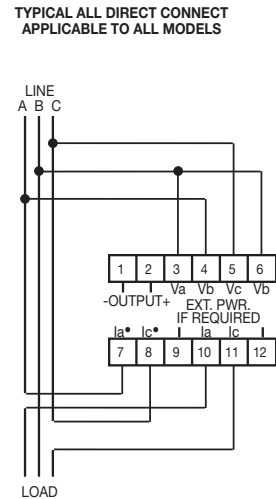
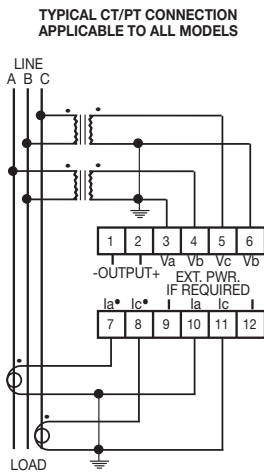
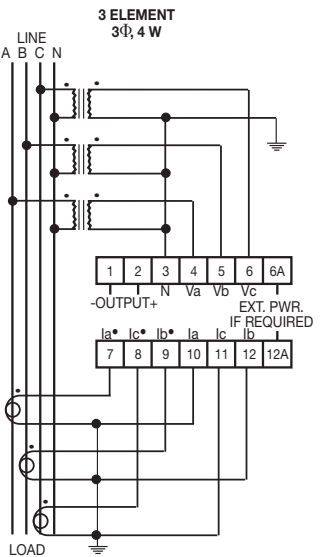
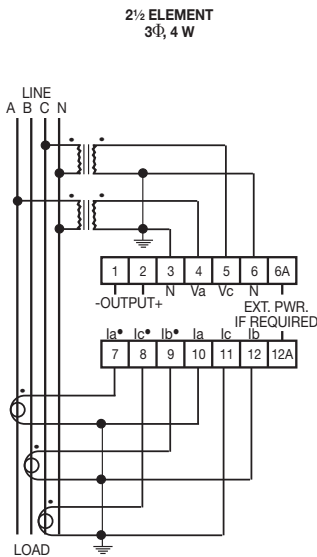
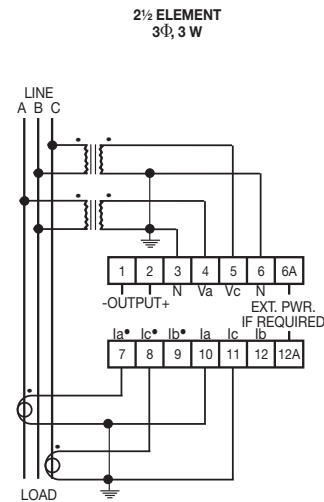
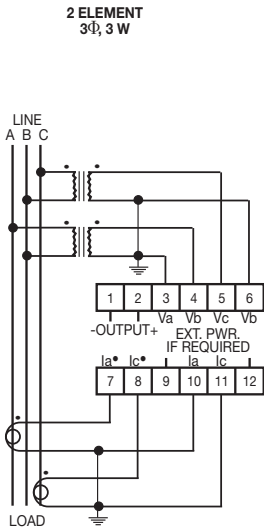
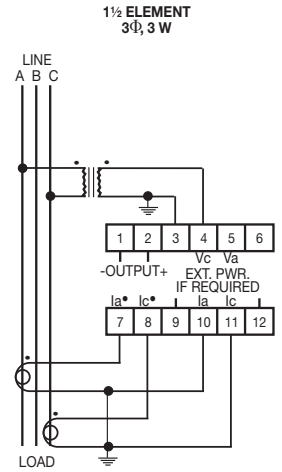
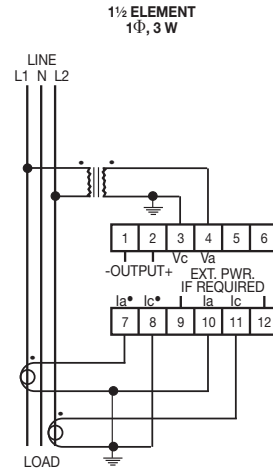
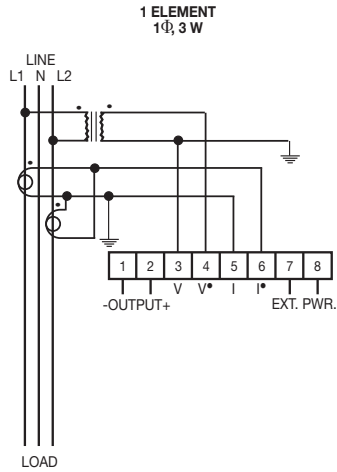
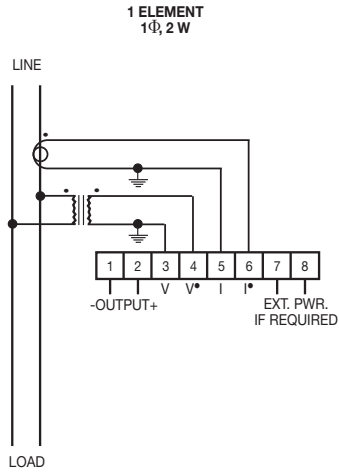

Attention:

If the transducer is mounted on a non-metallic or ungrounded surface the installer must provide the means for grounding and bonding as per NEC (National Electric Code) requirements.

AC Power Transducers (Combined W/R/Q)

Metal Surface Mount Cases

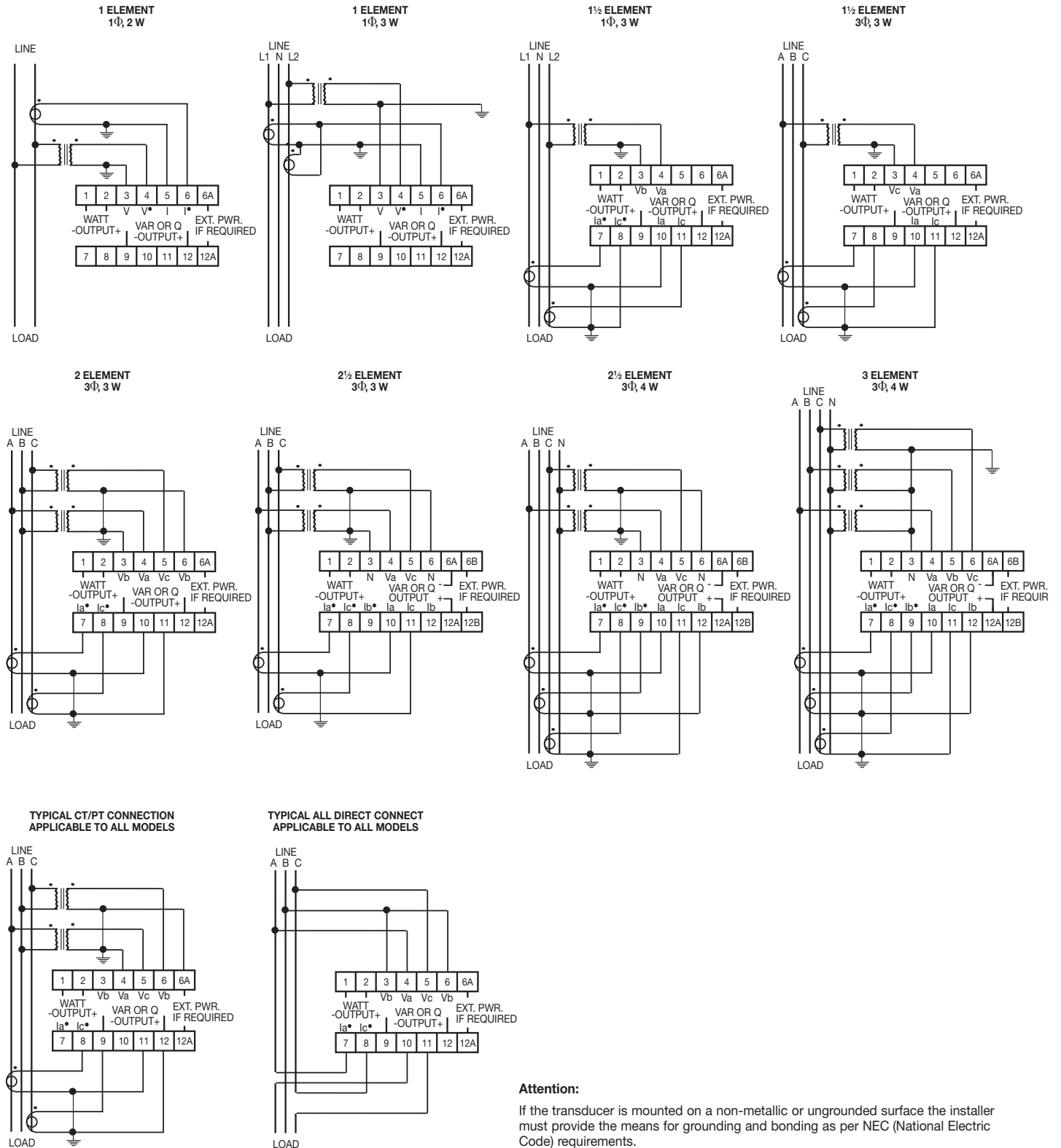

AC Energy Transducers (Single Output)

Metal Surface Mount Cases

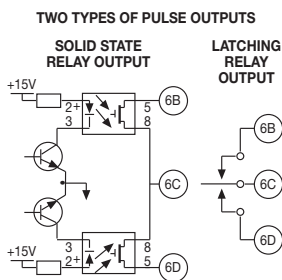
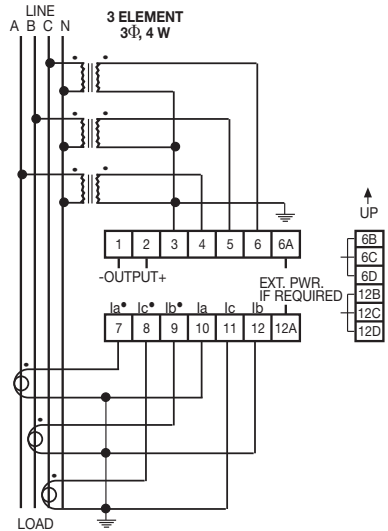
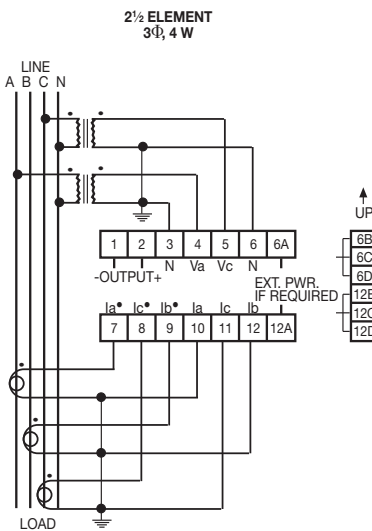
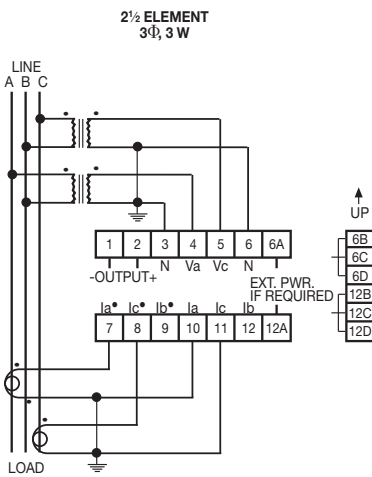
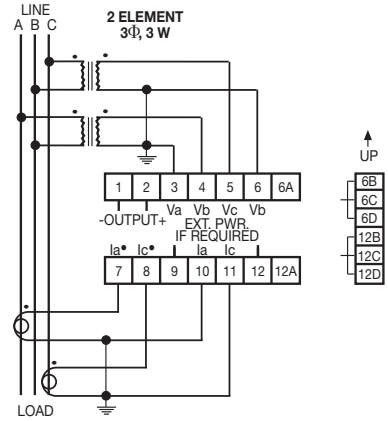
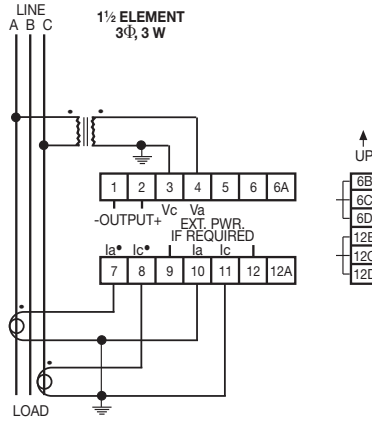
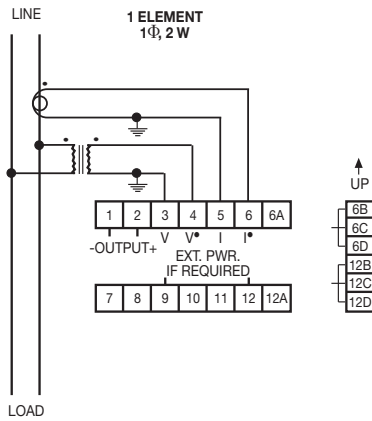

**TYPICAL ALL DIRECT CONNECT
APPLICABLE TO ALL MODELS**

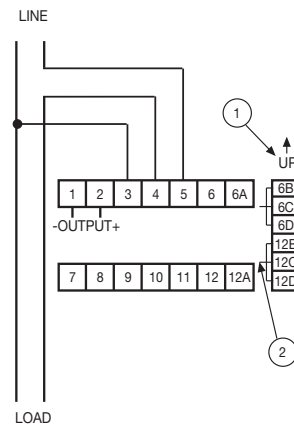

Notes:

- ① The arrow shows the direction of the mercury wetted relay output.
- ② The reverse direction is used only for bi-directional pulse outputs.

For supply connections use No. 14 AWG or larger wires rated for at least 75°C (167°F). Use copper conductors only.

Attention:

If the transducer is mounted on a non-metallic or ungrounded surface the installer must provide the means for grounding and bonding as per NEC (National Electric Code) requirements.

AC Energy Transducers (Combined W/R/Q)

Metal Surface Mount Cases

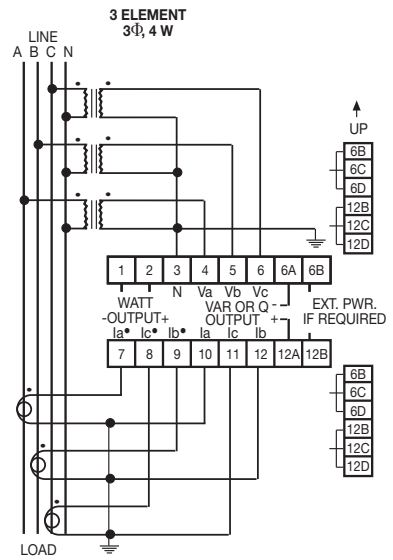
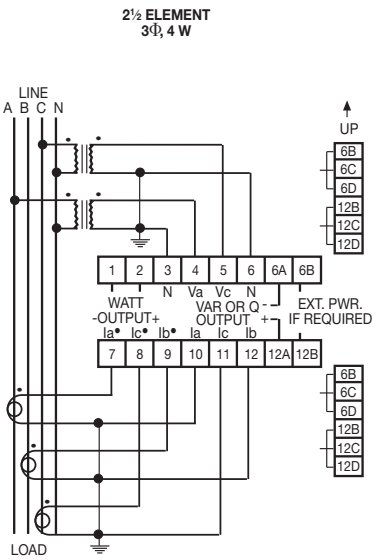
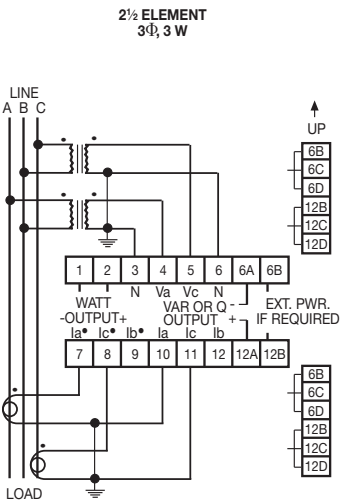
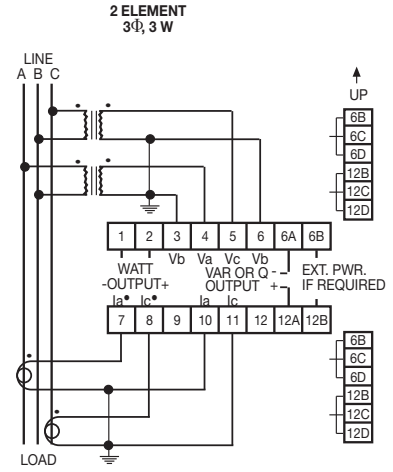
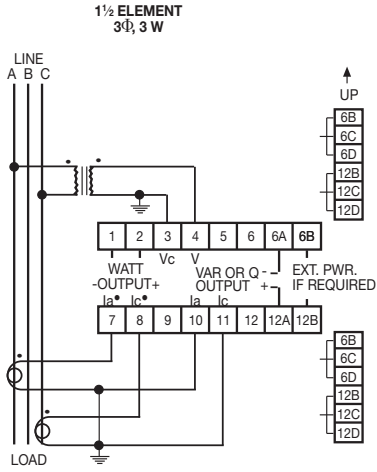
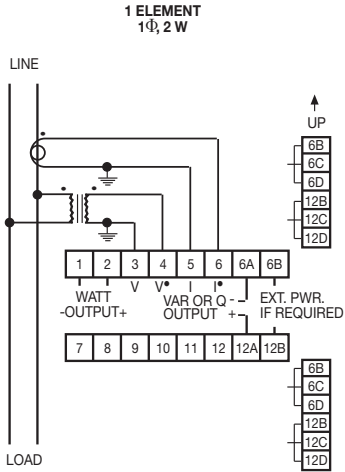

TWO TYPES OF PULSE OUTPUTS

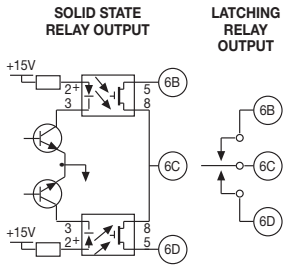

TYPICAL ALL DIRECT CONNECT APPLICABLE TO ALL MODELS

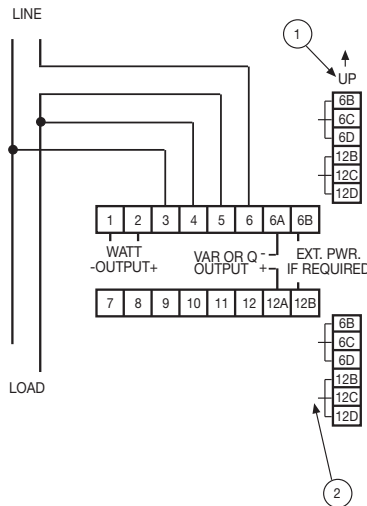

Notes:

- 1 The arrow shows the direction of the mercury wetted relay output.
- 2 The reverse direction is used only for bi-directional pulse outputs.

For supply connections use No. 14 AWG or larger wires rated for at least 75°C (167°F). Use copper conductors only.

Attention:

If the transducer is mounted on a non-metallic or ungrounded surface the installer must provide the means for grounding and bonding as per NEC (National Electric Code) requirements.

Power Factor/Phase Angle Transducers

DIN Rail Mount Cases

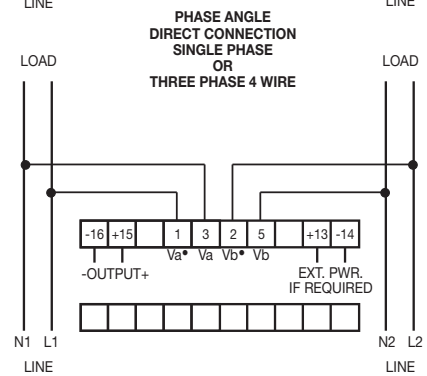
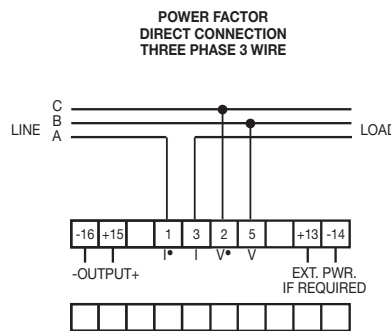
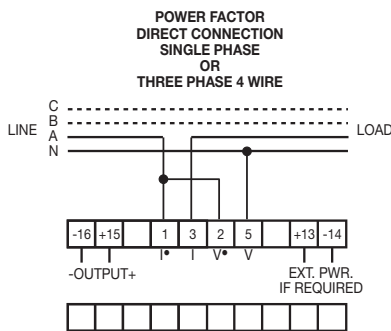
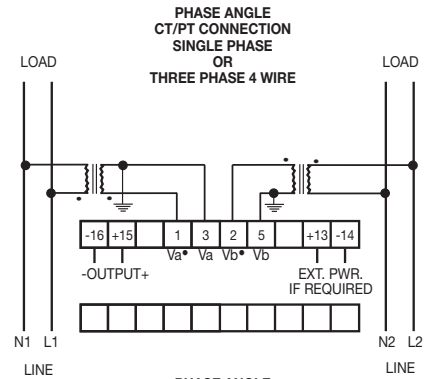
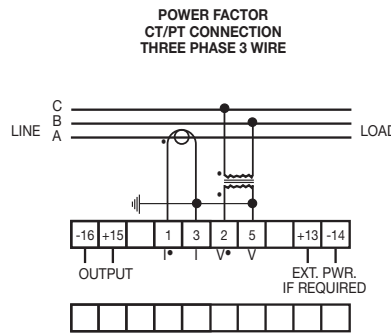
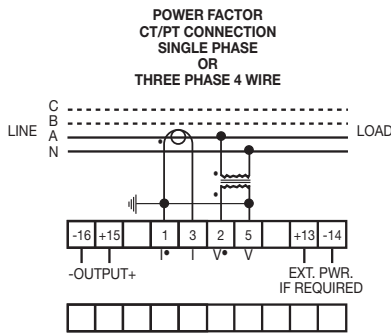

Metal Surface Mount Cases

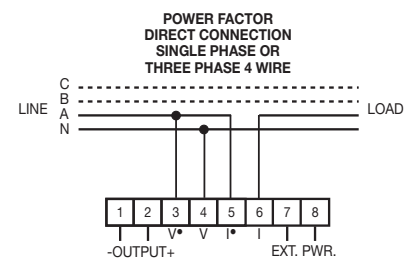
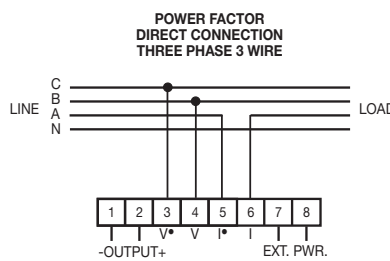
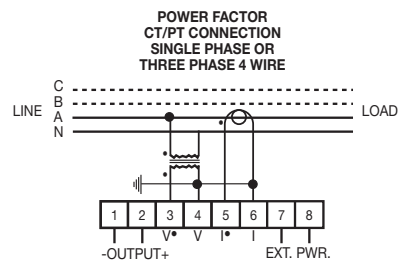
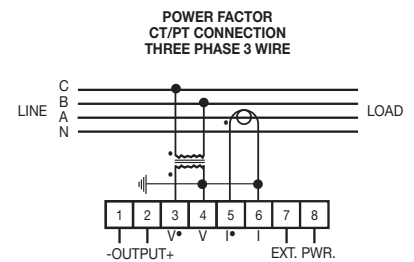
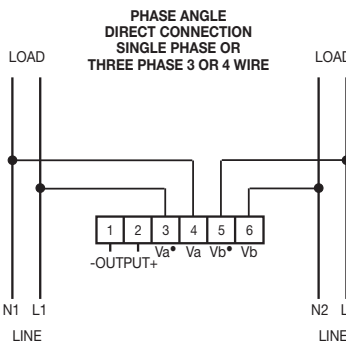
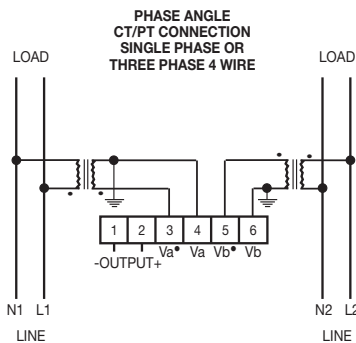

Notes:

1. For supply connections use No. 14 AWG or larger wires rated for at least 75°C (167°F). Use copper conductors only.
2. Power factor transducers do not understand physics and do not know that power factor cannot exceed 90 degrees.
3. If reading appears to be out of range, reverse current or potential leads to suit.
4. Direct connect transducers are available to 600 VAC and/or 25 A(ac).

5. Phases can be rotated on three phase units.

6. It is good practice to use ring lugs on current circuits.

7. It is good practice to connect one side of the PT and CT to earth ground.

Attention:

If the transducer is mounted on a non-metallic or ungrounded surface the installer must provide the means for grounding and bonding as per NEC (National Electric Code) requirements.

Frequency Transducers

DIN Rail Mount Cases

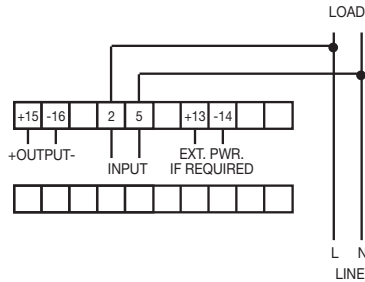

Metal Surface Mount Cases

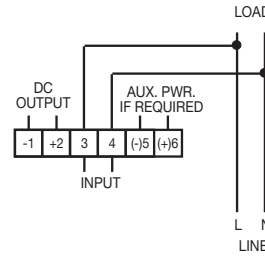

RTD/Slidewire Transducers

DIN Rail Mount Cases

SLIDEWIRE TRANSDUCER

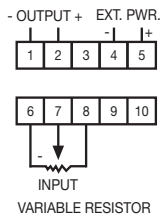

RTD TRANSDUCER

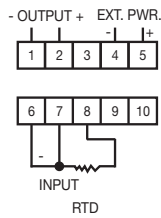

Metal Surface Mount Cases

SLIDEWIRE TRANSDUCER

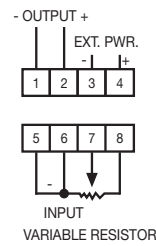

RTD TRANSDUCER

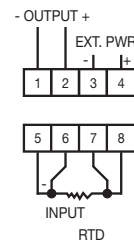

DC Voltage Transducers/Ground Fault Detectors

DIN Rail Mount Cases

DC CURRENT/VOLTAGE TRANSDUCER

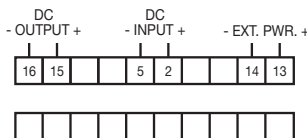

Metal Surface Mount Cases

DC VOLTAGE TRANSDUCER

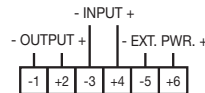

DC VOLTAGE TRANSDUCER AND GROUND FAULT DETECTOR

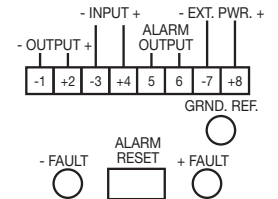

Notes:

1. For supply connections use No. 14 AWG or larger wires rated for at least 75°C (167°F). Use copper conductors only.

Attention:

If the transducer is mounted on a non-metallic or ungrounded surface the installer must provide the means for grounding and bonding as per NEC (National Electric Code) requirements.

Line Post Sensor Transducers/Fault Alarms

Metal Surface Mount Cases

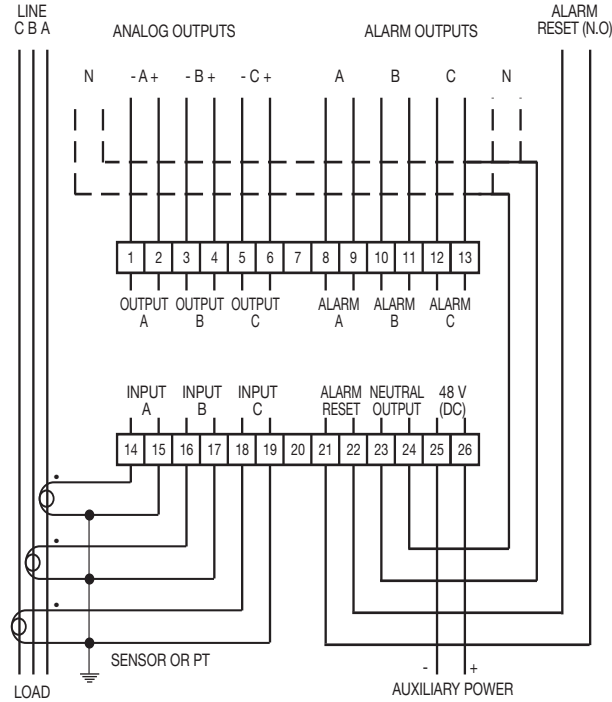

Notes:

1. All transducers need an auxiliary power source.
2. Not all connections are available on all models. Unused terminals are left unconnected internally.
3. The polarity indicated for the alarm reset terminals applies to solid-state switching device.
4. The polarity indicated for the auxiliary power applies to DC sources.

5. The negative terminals of all analog outputs and the alarm reset are common internally.

Attention:

If the transducer is mounted on a non-metallic or ungrounded surface the installer must provide the means for grounding and bonding as per NEC (National Electric Code) requirements.

Line Post Sensor Transducer Systems

